

kiwa

No. 2268



EN 1090-1:2009+A1:2011
No. 2268-CPR-419

ONION

CZ Návod na montáž skleníku ONION

SK Návod na montáž skleníka ONION

HU ONION üvegház összeszerelési útmutató

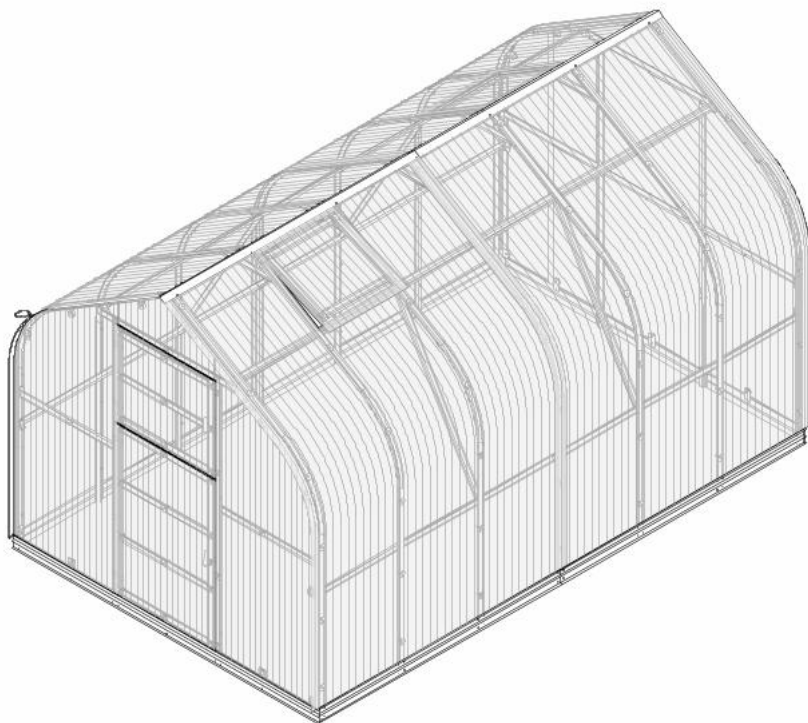

CZ

Skleníky ONION získaly certifikát CE, který vydala společnost UAB „KIWA inspecta“. Na základě tohoto certifikátu prohlašujeme, že při výrobním procesu dodržujeme třídu provedení prací EXC2 podle normy EN 1090-1:2009+A1:2011, pozinkovaná ocel podle normy EN10346: DX51D+Z bez svařovacích procesů.

Upozornění!

Při montáži rámu skleníku a při práci s polykarbonátem vždy noste ochranné rukavice.

K montáži skleníku budete potřebovat:

- * Šestihranný klíč o průměru 8 mm nebo klíč s otevřeným koncem;
- * Šroubovák s křížovou hlavou nebo akumulátorový šroubovák;
- * Lopatu k upevnění skleníku do země;
- * Vodováhu pro měření rovnosti;
- * Provázek pro měření úhlopříčky;
- * Nůž pro řezání polykarbonátových desek;

Při stavbě skleníku je důležité vybrat vhodné místo a řídit se předpisy pro územní plánování.

ZÁRUKY A PODMÍNKY VÝROBCE

Veškeré záruky, podmínky vrácení zboží a aktuální a důležité informace o postupu montáže najdete na webových stránkách www.zahradajezek.cz.

SK

Skleníky ONION získali certifikát CE, ktorý vydala spoločnosť UAB „KIWA inspecta“. Na základe tohto certifikátu vyhlasujeme, že pri výrobnom procese dodržiavame triedu vykonania prác EXC2 podľa normy EN 1090-1:2009+A1:2011, pozinkovaná oceľ podľa normy EN 10346: DX51D+Z bez zvaráčich procesov.

Upozornění!

Pri montáži rámu skleníka a pri práci s polykarbonátom vždy noste ochranné rukavice.

Na montáž skleníka budete potrebovať:

- * Šesťhranný kľúč s priemerom 8 mm alebo vidlicový kľúč;
- * Skrutkovač s křížovou hlavou alebo akumulátorový skrutkovač;
- * Lopatu na upevnenie skleníka do zeme;
- * Vodováhu na meranie rovinnosti;
- * Povrázok na meranie uhlopriečky;
- * Nôž na rezanie polykarbonátových dosiek;

Pri stavbe skleníka je dôležité vybrať vhodné miesto a riadiť sa predpismi územného plánovania.

ZÁRUKA VÝROBCU A PODMIENKY

Všetky záruky, podmienky vrátenia tovaru a aktuálne a dôležité informácie o postupe montáže nájdete na webovej stránke www.odsuseda.sk

HU

Az ONION üvegházak CE tanúsítvánnyal rendelkeznek, amelyet az UAB „KIWA inspecta” vállalat állított ki. A tanúsítvány alapján kijelentjük, hogy a gyártási folyamat során betartjuk az EN 1090-1:2009+A1:2011 szabvány szerinti EXC2 kivitelezési osztályt, valamint az EN 10346: DX51D+Z szabványnak megfelelő horganyzott acélt alkalmazunk, hegesztési eljárások nélkül.

Figyelem!

Az üvegház vázának összeszerelésekor és a polikarbonáttal való munkavégzés során mindig viseljen védőkesztyűt.

Az üvegház összeszereléséhez a következőkre lesz szükség:

- * 8 mm átmérőjű imbuszkulcs vagy villáskulcs;
- * Keresztfejű csavarhúzó vagy akkumulátoros csavarozó;
- * Ásó az üvegház talajhoz rögzítéséhez;
- * Vízérték a síkellenőrzéshez;
- * Zsinór az átlók méréséhez;
- * Kés a polikarbonát lemezek vágásához;



















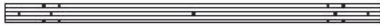

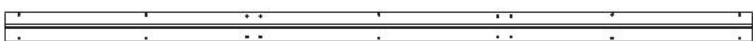
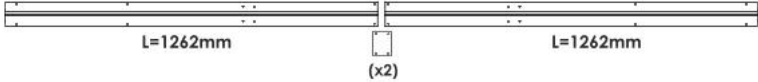
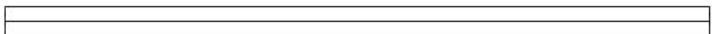

Az üvegház építéskor fontos a megfelelő hely kiválasztása, valamint a területrendezési és építési előírások betartása.

A GYÁRTÓ GARANCIÁI ÉS FELTÉTELEI

A garanciákra, az áru visszaküldésének feltételeire, valamint az összeszerelési eljárással kapcsolatos aktuális és fontos információkra vonatkozó részletek a www.jeza.hu weboldalon találhatóak.

5m²

SKLENÍK ONION – SEZNAM DÍLŮ / SKLENÍK ONION – ZOZNAM DIELOV ONION ÜVEGHÁZ – ALKATRÉSZLISTA

- 1 (x8)  L=1070mm
- 2 (x8)  L=730mm
- 3 (x8)  L=1600mm
- 4 (x12)  L=200mm
- 5 (x4)  L=2000mm
- 7 (x2)  L=1330mm
- 8 (x2)  L=450mm
- 9A (x4)  L=370mm
- 9 (x4)  L=2020mm
- 10 (x2)  L=1120mm
- 11.1 (x4)  L=770mm
- 12 (x1)  L=820mm
- 13 (x1)  L=620mm
- 15 (x2)  L=2000mm
- 17 (x2)  L=2525mm
- 
L=1262mm (x2) L=1262mm
- 23 (x2)  L=2100mm
- 33 (x2)  L=2000mm
- D1 (x1)  L=670mm
- D2 (x1)  L=670mm
- D3 (x3)  L=715mm
- D4 (x1)  L=1220mm
- D5 (x1)  L=1220mm
- S1 (x1)  L=520mm
- S2 (x1)  L=520mm
- S3 (x2)  L=550mm

5m² SKLENÍK ONION – SEZNAM DÍLŮ / SKLENÍK ONION – ZOZNAM DIELOV ONION ÜVEGHÁZ – ALKATRÉSZLISTA

18 (x4)

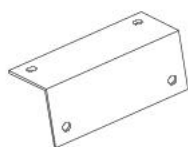

19 (x4)

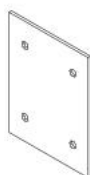

20 (x20)



21 (x8)



22 (x5)



31 (x124)



30 (x8)



14 (x4)

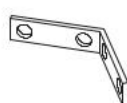

29 (x401)
M5



26 (x269)
M5-12



27 (x29)
M5-16



28 (x103)
M5-40



36 (12m)

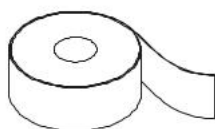

32 (x1)



35 (x2)

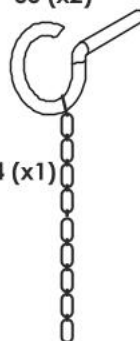

24 (x2)

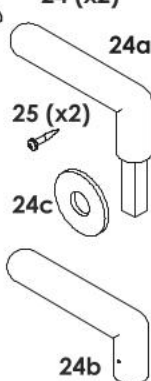

25 (x2)



24c

24b

34 (x1)

Polykarbonátová deska / Polykarbonátová doska /
Polikarbonát lemez

(x2)
2100x6000 mm



2 m PRODLOUŽENÍ SKLENÍK ONION
2 m PREDĽŽENIE SKLENÍK ONION
2 m-es ONION ÜVEGHÁZ HOSSZABBÍTÁS

5m²

Prodoužení 5 m² /
Predĺženie 5 m² /
5m²-es hosszabbítás

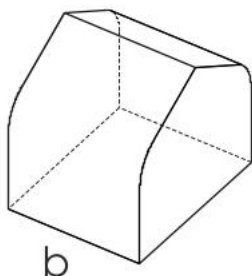

5m²



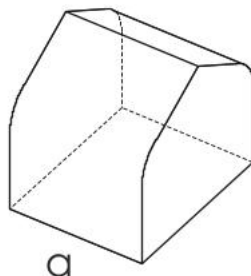



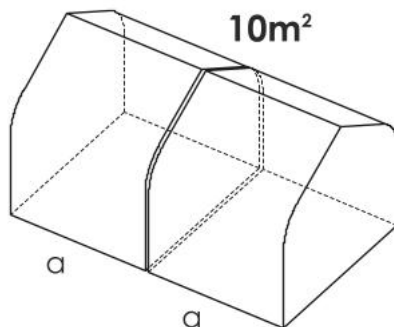
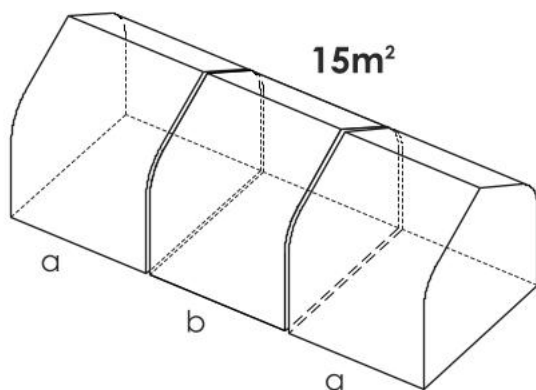











Základní modul 5 m² /
Základný modul 5 m² /
5 m² Alapmodul

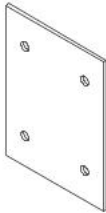
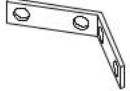

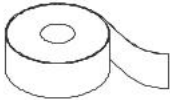
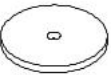
2 m PRODLOUŽENÍ SKLENÍK ONION. UKÁZKA MONTÁŽE /
2 m PREDĽŽENIE SKLENÍK ONION – UKÁŽKA MONTÁŽE /
2 m ONION ÜVEGHÁZ HOSSZABBÍTÁS – ÖSSZESZERELÉSI MINTA



2 m PRODLOUŽENÍ SKLENÍK ONION. SEZNAM DÍLŮ /
2 m PREDĽŽENIE SKLENÍK ONION – ZOZNAM DIELOV /
2 m ONION ÜVEGHÁZ HOSSZABBÍTÁS – ALKATRÉSZLISTA

| | | |
|-----------|--|----------|
| 1 (x6) |  | L=1070mm |
| 2 (x6) |  | L=730mm |
| 3 (x6) |  | L=1600mm |
| 4 (x6) |  | L=200mm |
| 5 (x4) |  | L=2030mm |
| 7 (x2) |  | L=1330mm |
| 8 (x3) |  | L=450mm |
| 13 (x1) |  | L=625mm |
| 16 (x2) |  | L=1965mm |
| 23 (x2) |  | L=2100mm |
| 19 (x2) |  | |
| 14 (x3) |  | |
| 37 (x2) |  | |
| 32 (x1) |  | |
| 31 (x40) |  | |
| 26 (x108) | | |
| M5-12 |  | |
| 27 (x6) | | |
| M5-16 |  | |
| 28 (x44) | | |
| M5-40 |  | |
| 29 (x154) | | |
| M5 |  | |
| 30 (x6) | | |
| |  | |

(x1)
700x650 mm

Polykarbonátová deska /
 Polykarbonátová doska /
 Polikarbonát lemez

S1 (x1)  L=520mm

S2 (x1)  L=520mm















S3 (x2)  L=550mm

Polykarbonátová deska / Polykarbonátová doska /
 Polikarbonát lemez







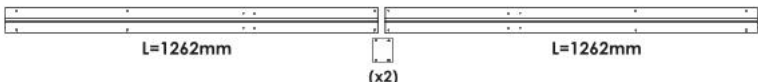

(x1)
2100x6000 mm

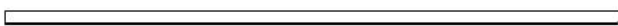
10m² SKLENÍK ONION – SEZNAM DÍLŮ / SKLENÍK ONION – ZOZNAM DIELOV

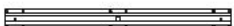
ONION ÜVEGHÁZ – ALKATRÉSZLISTA

- 1 (x14)  L=1070mm
- 2 (x14)  L=730mm
- 3 (x14)  L=1600mm
- 4 (x18)  L=200mm
- 5 (x8)  L=2030mm
- 7 (x4)  L=1330mm
- 8 (x5)  L=450mm
- 9A (x4)  L=370mm
- 9 (x4)  L=2020mm
- 10 (x2)  L=1120mm
- 11.1 (x4)  L=770mm
- 12 (x1)  L=820mm
- 13 (x2)  L=620mm
- 15 (x4)  L=2000mm
- 17 (x2)  L=2525mm

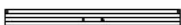

L=1262mm (x2) L=1262mm
- 23 (x4)  L=2100mm
- 33 (x1)  L=2000mm
- D1 (x1)  L=670mm
- D2 (x1)  L=670mm
- D3 (x7)  L=715mm
- D4 (x1)  L=1220mm
- D5 (x1)  L=1220mm
- S1 (x2)  L=520mm
- S2 (x2)  L=520mm
- S3 (x4)  L=550mm

10m² SKLENÍK ONION – SEZNAM DÍLŮ / SKLENÍK ONION – ZOZNAM DIELOV ONION ÜVEGHÁZ – ALKATRÉSZLISTA

18 (x4)

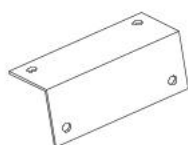

19 (x6)

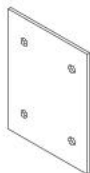

20 (x20)

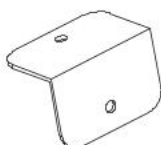

21 (x8)

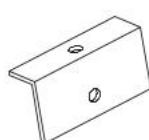

22 (x5)



31 (x164)



30 (x14)



14 (x7)



29 (x559)
M5



26 (x377)
M5-12



27 (x35)
M5-16



28 (x147)
M5-40



36 (12m)

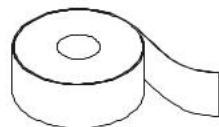

32 (x1)

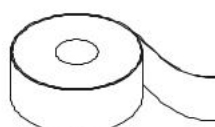

35 (x2)

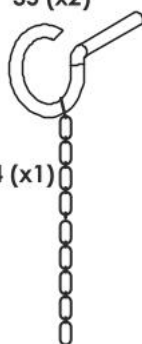

34 (x1)



24 (x2)

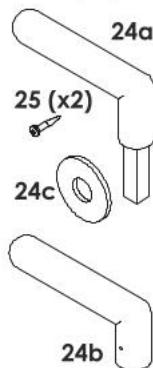

24a

25 (x2)

24c

24b

Polykarbonátová deska / Polykarbonátová doska /
Polikarbonát lemez
(x3)
2100x6000 mm



1

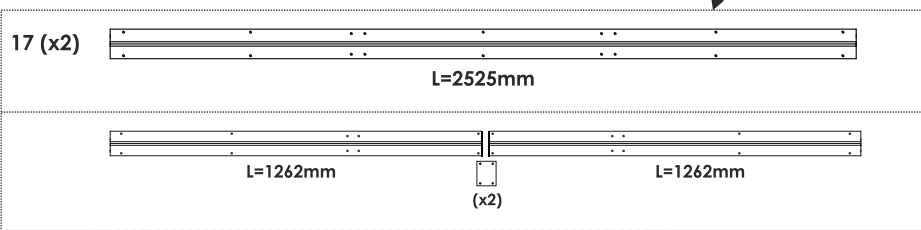
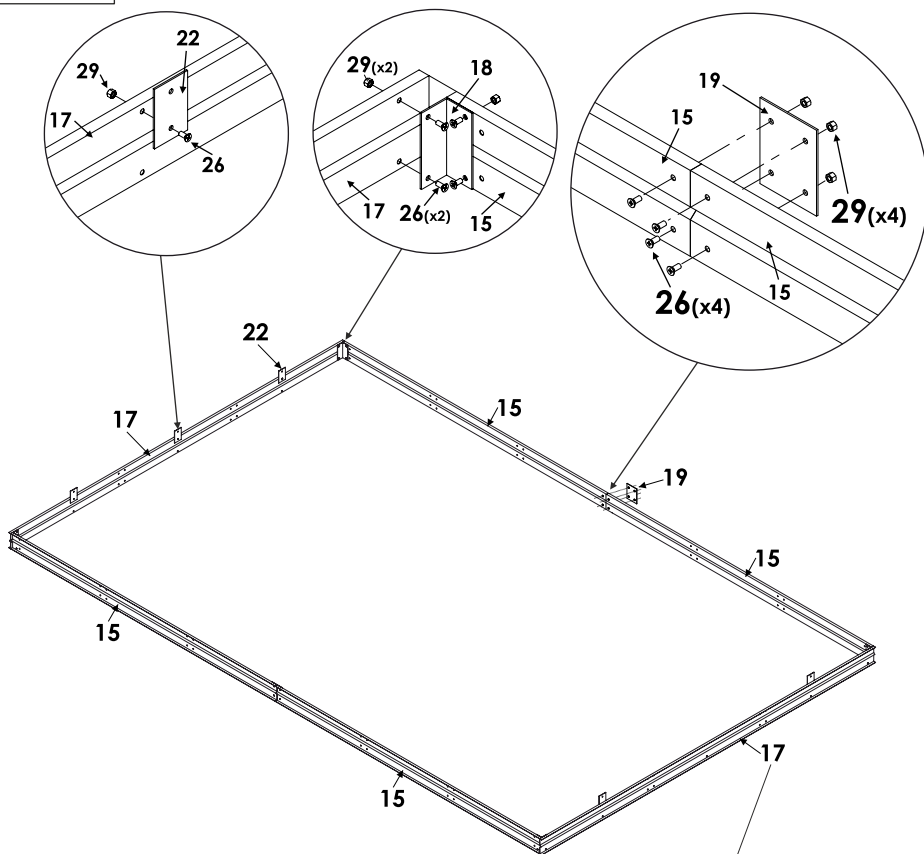

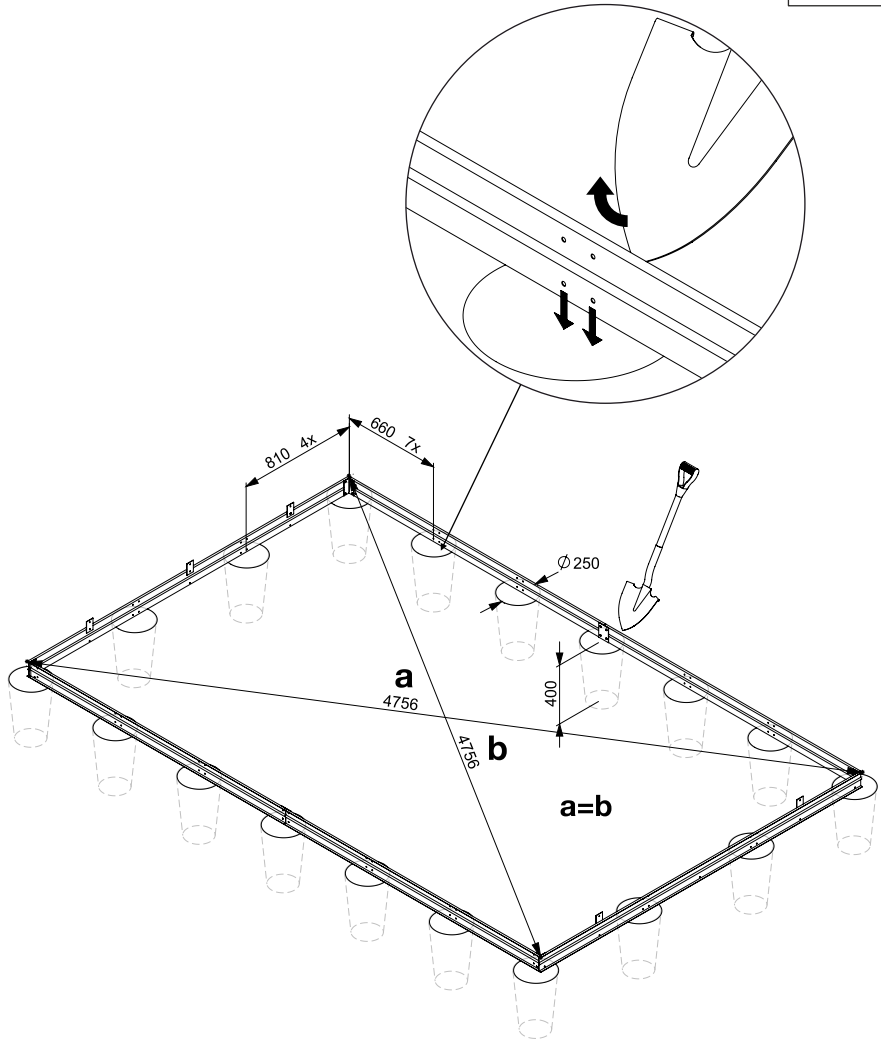

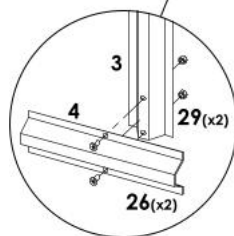
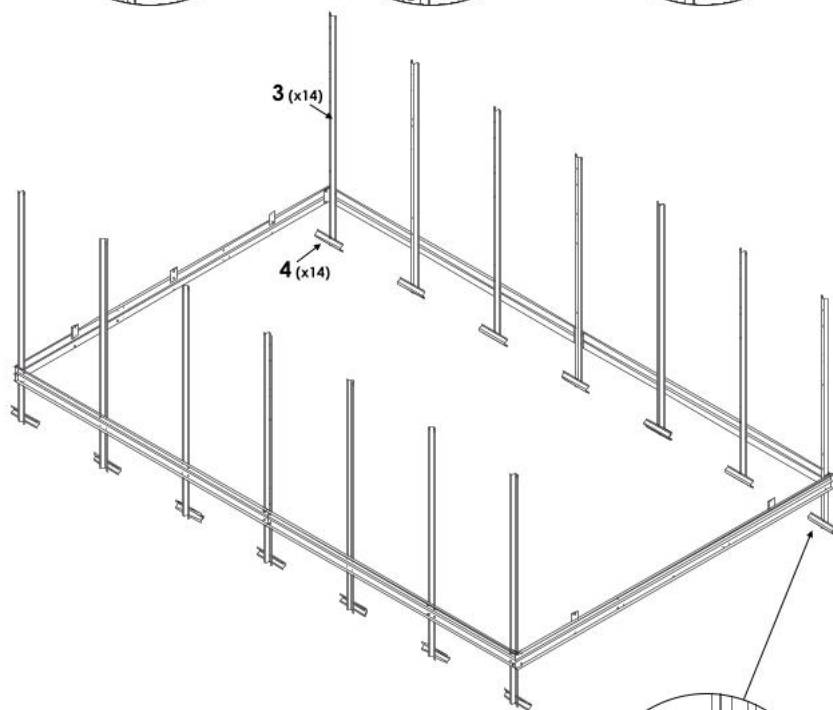
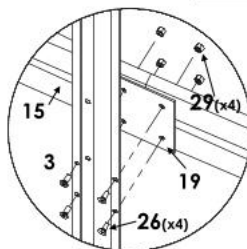
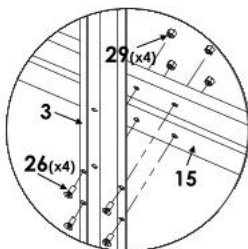
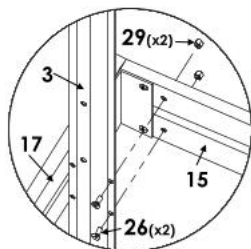

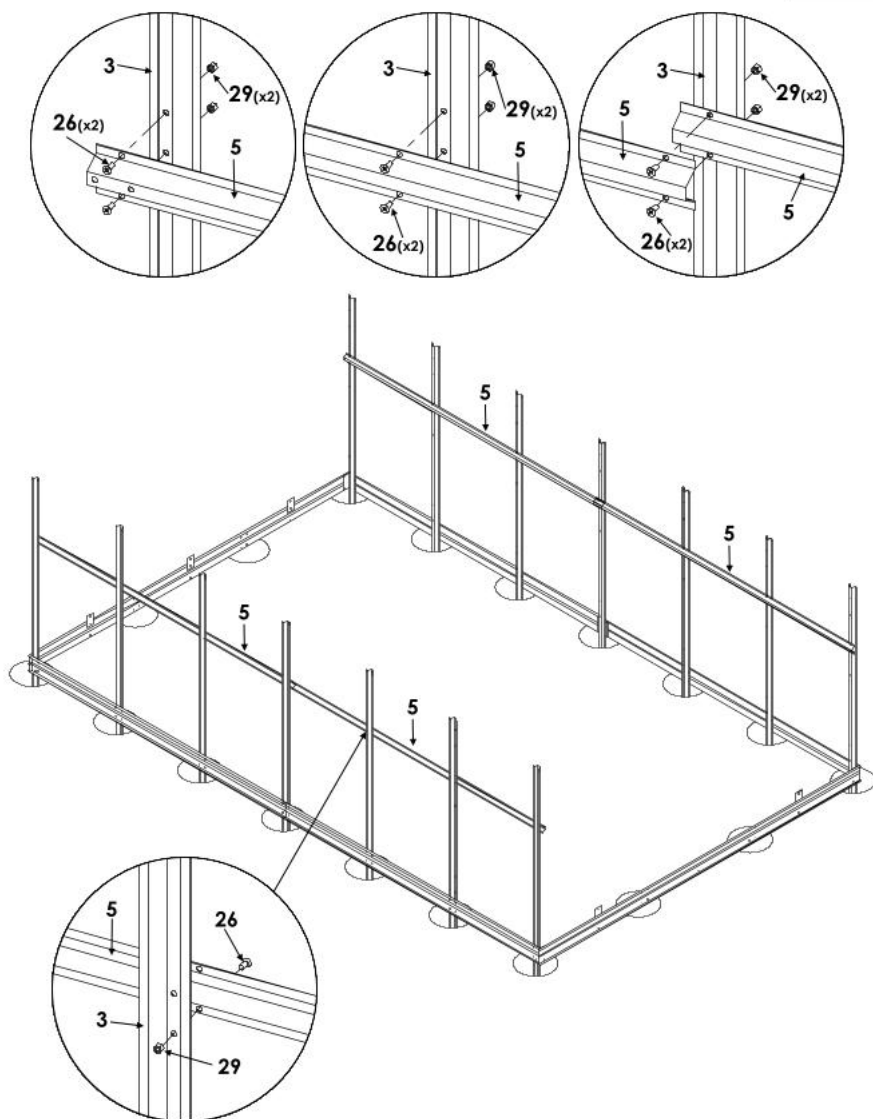

5

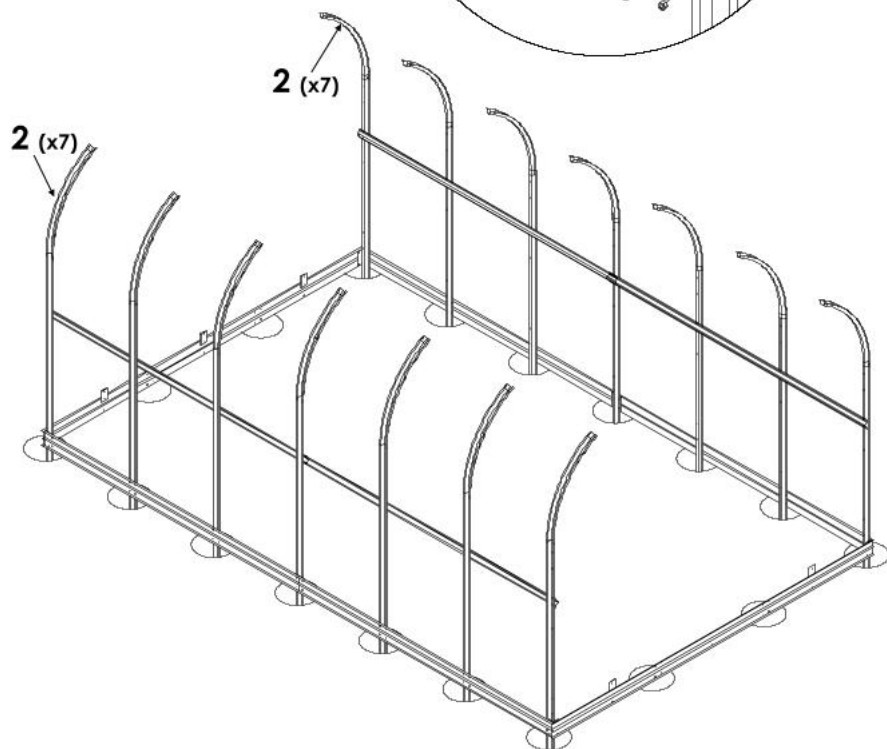
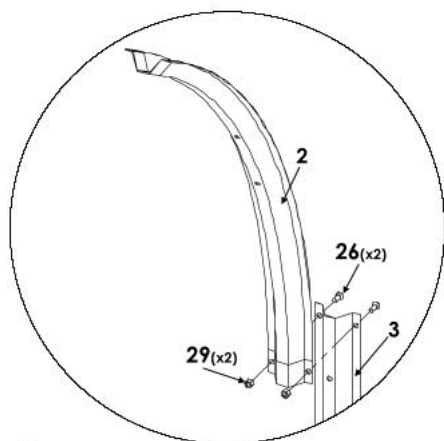

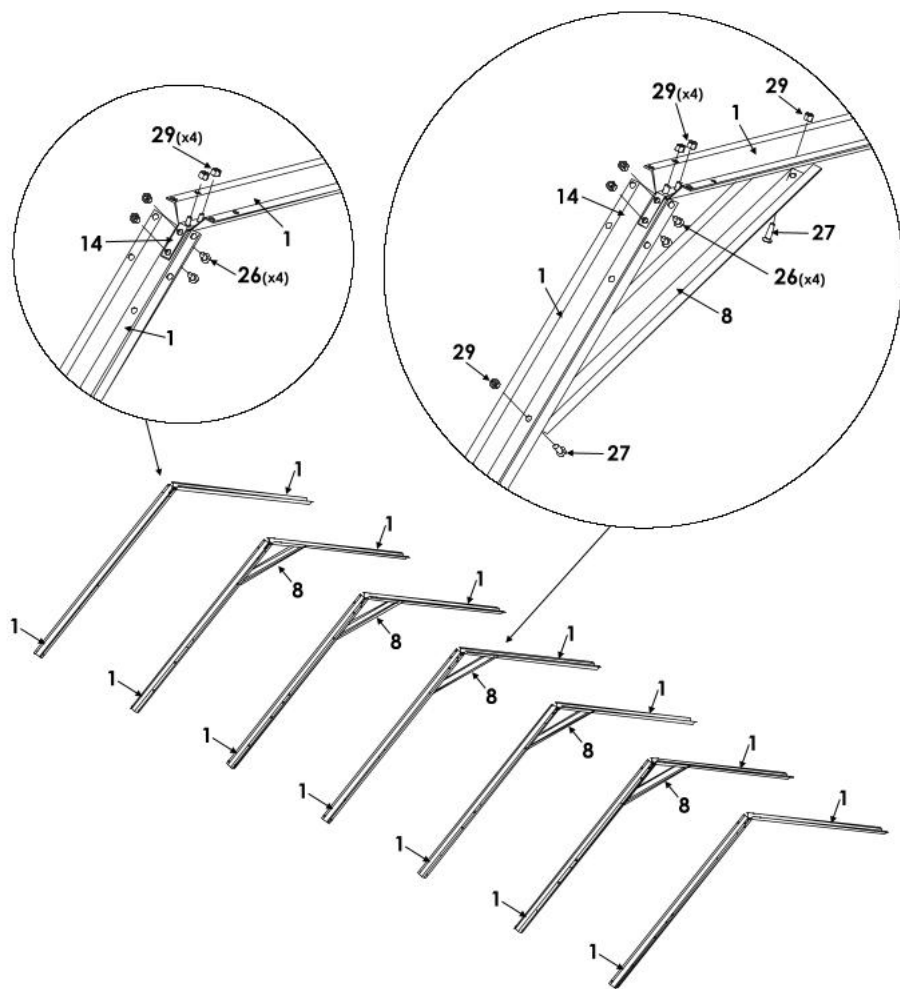

7

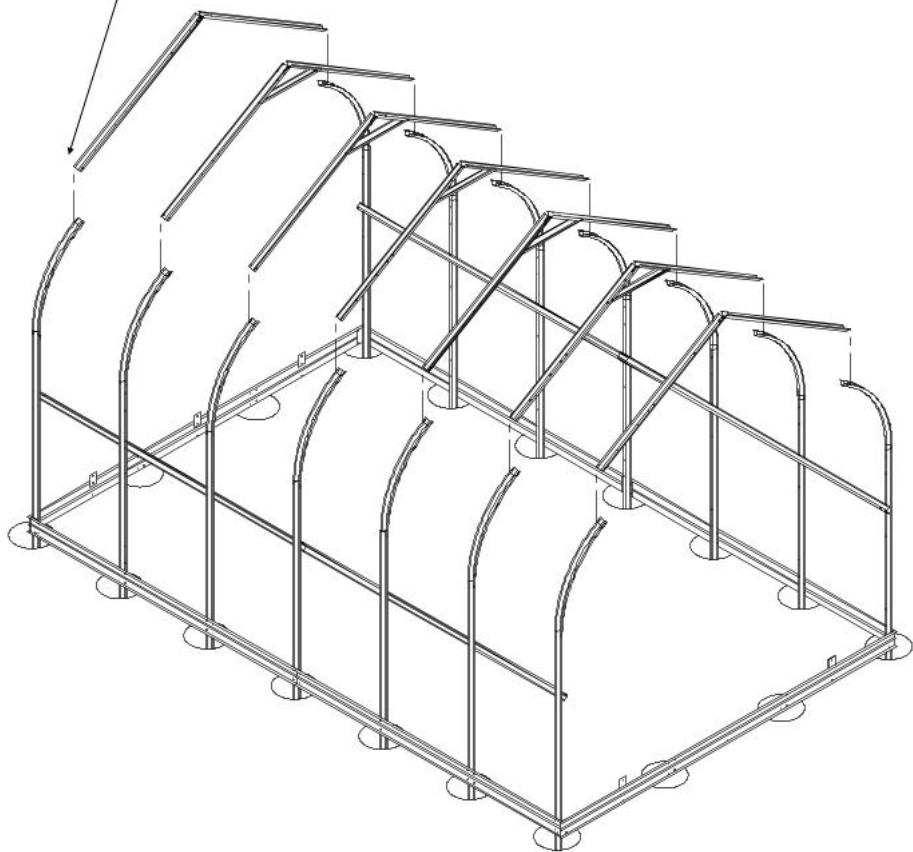
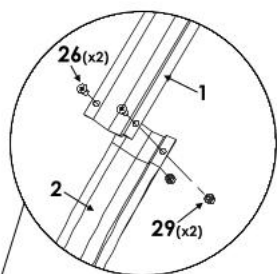

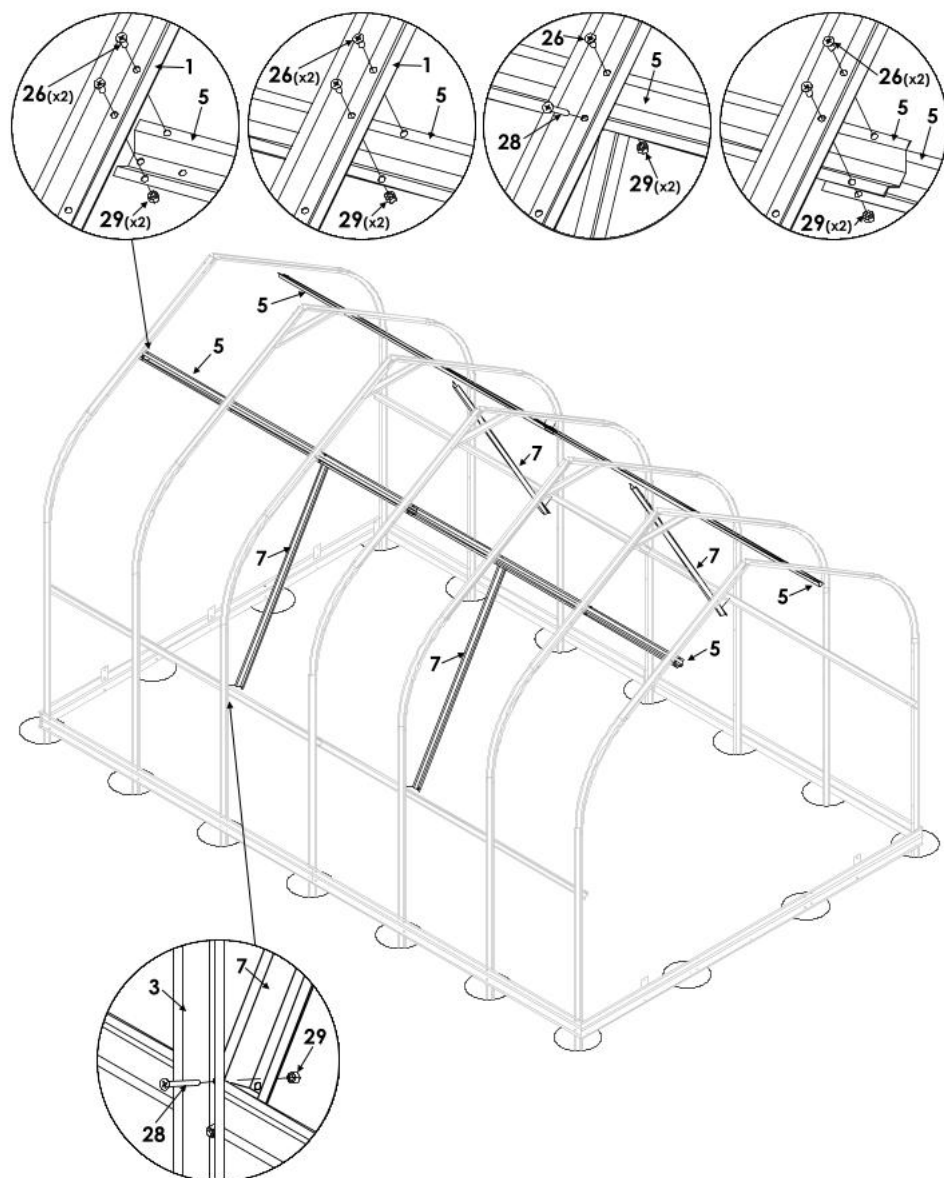

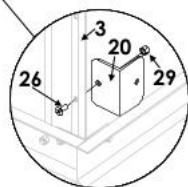
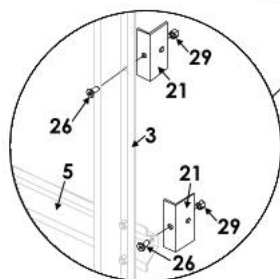
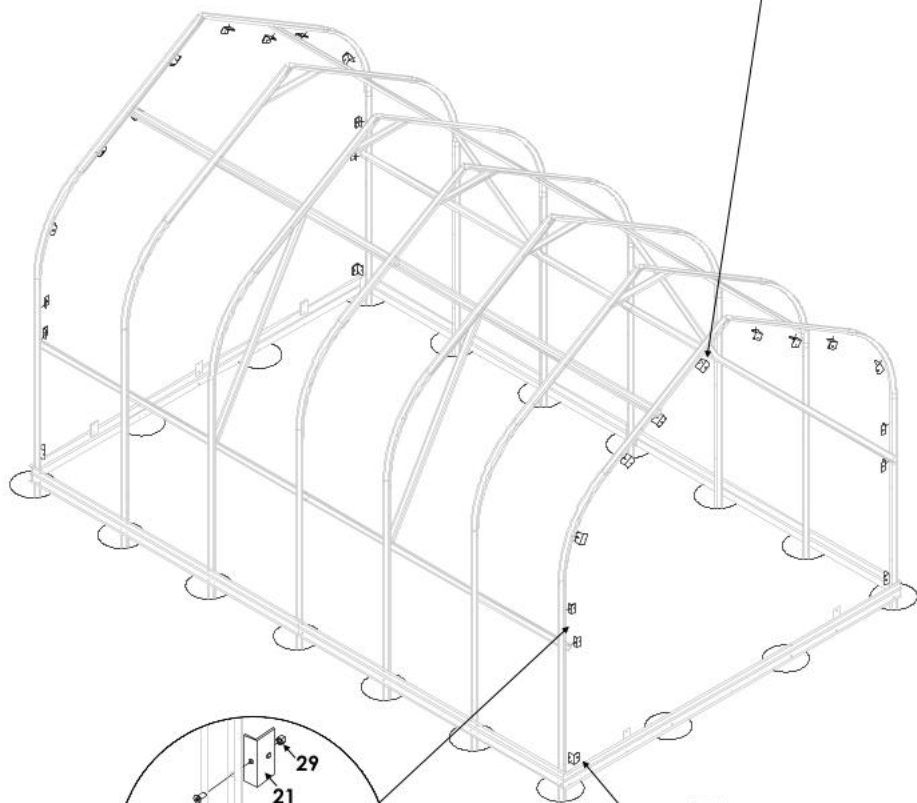
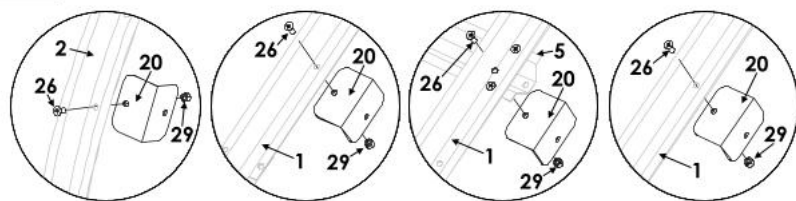

10

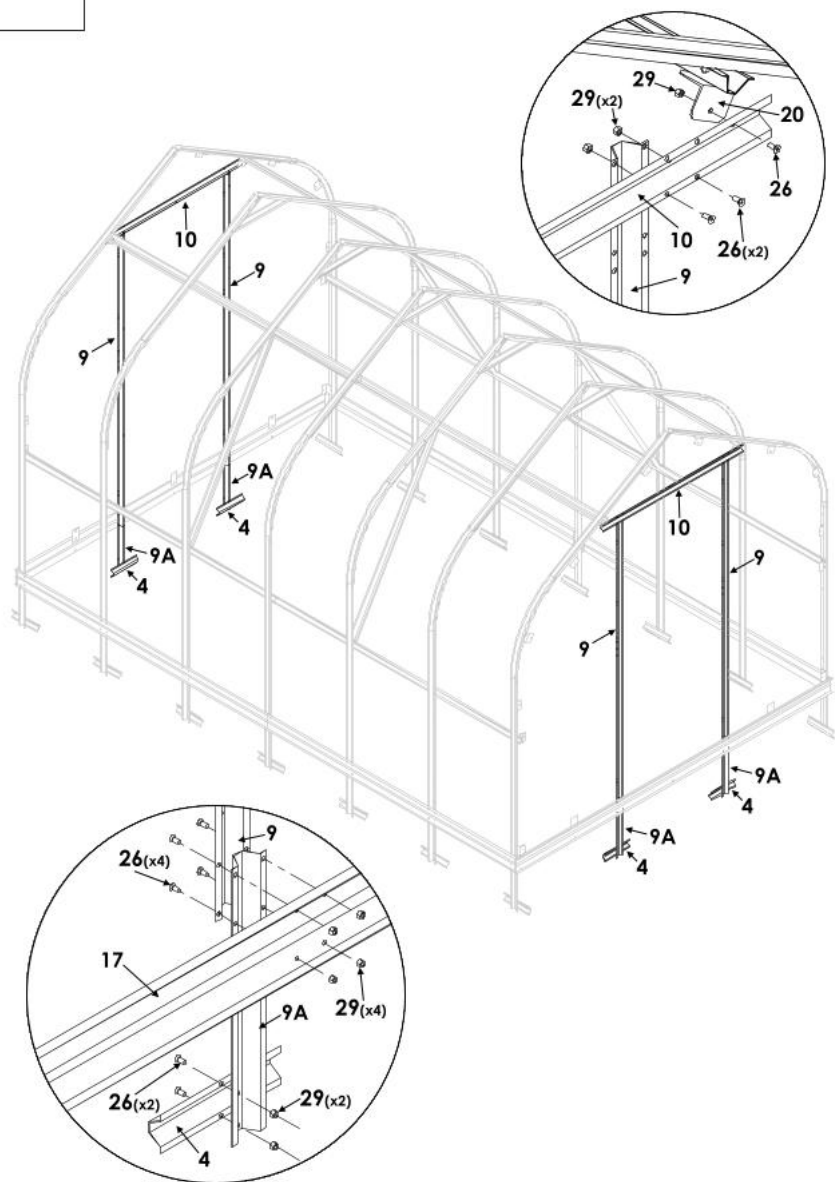

11

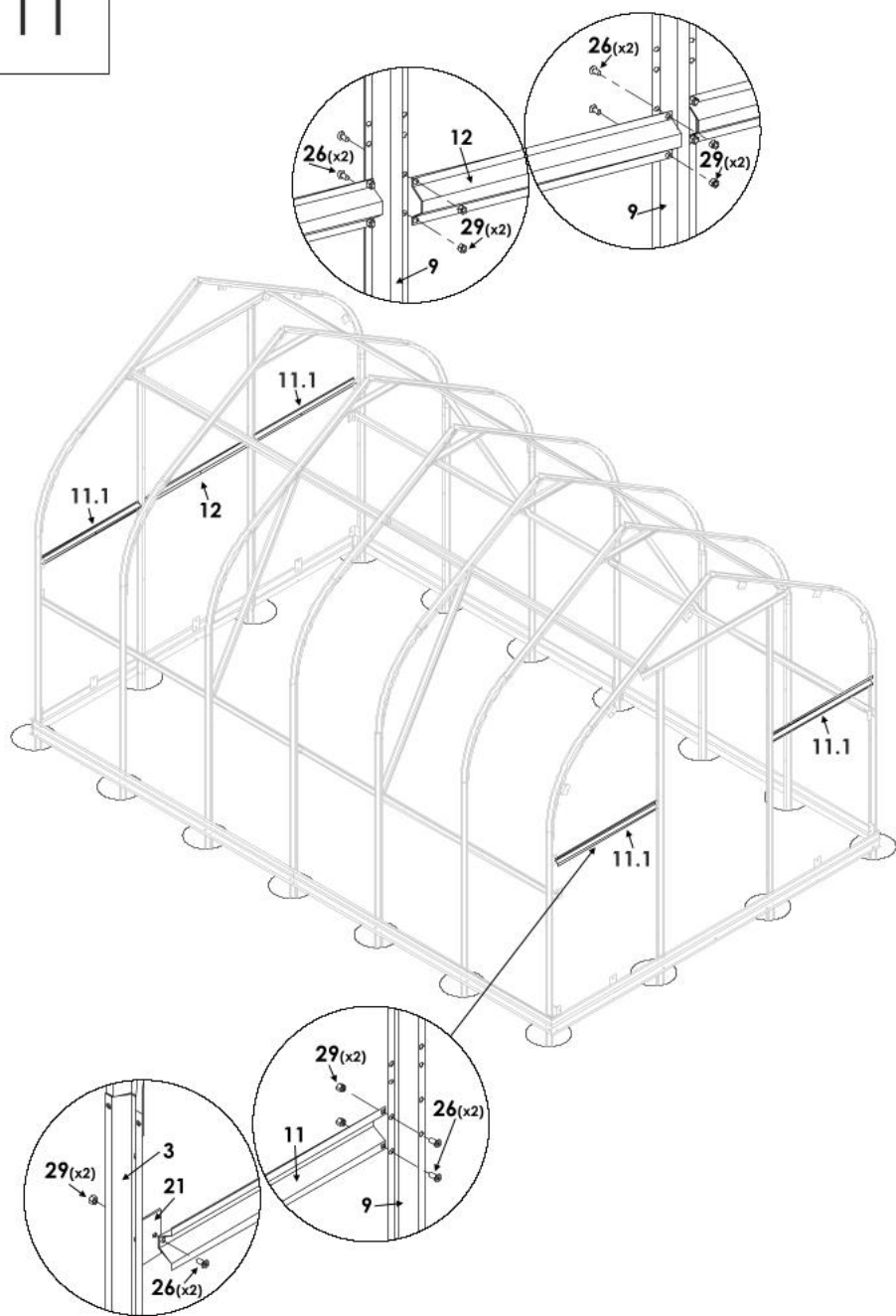

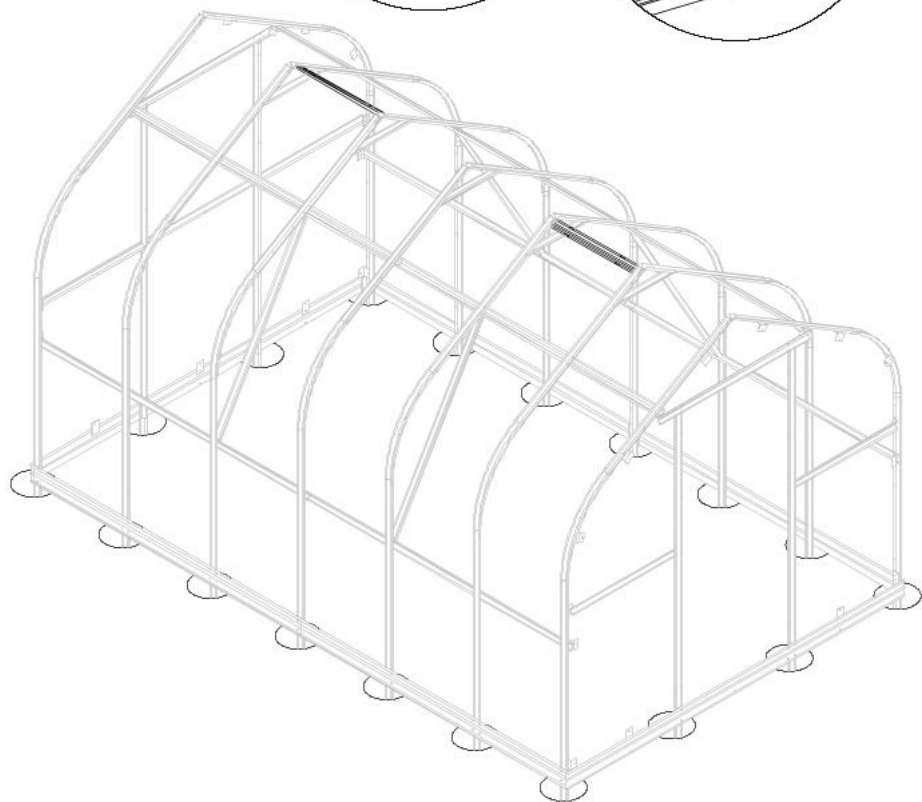
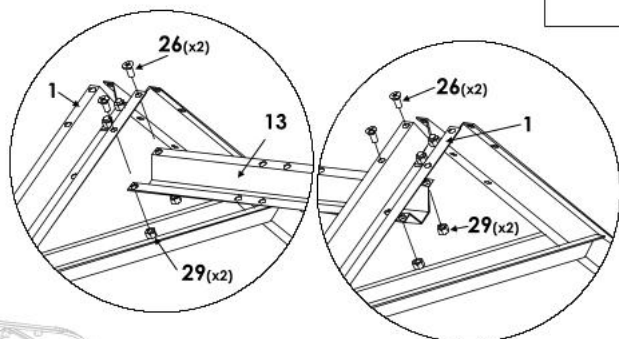

13

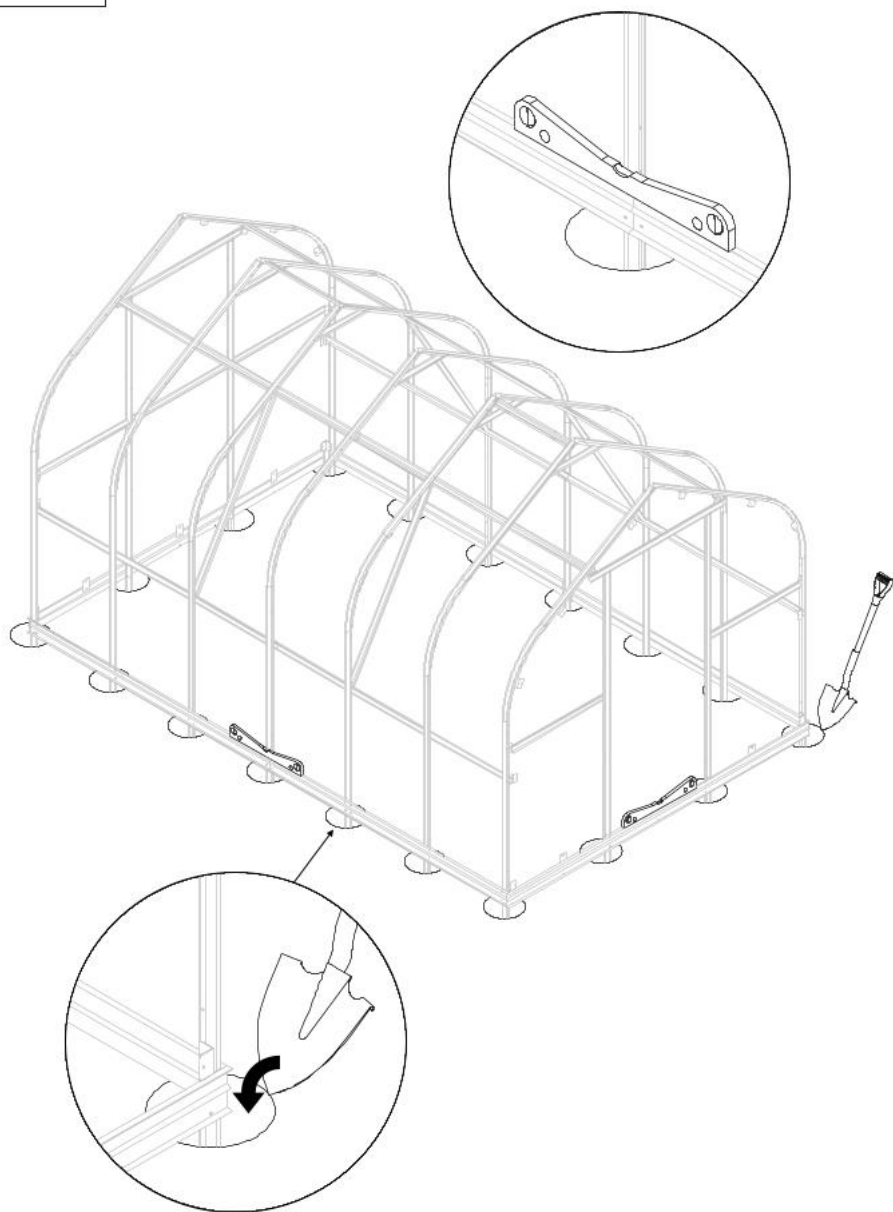

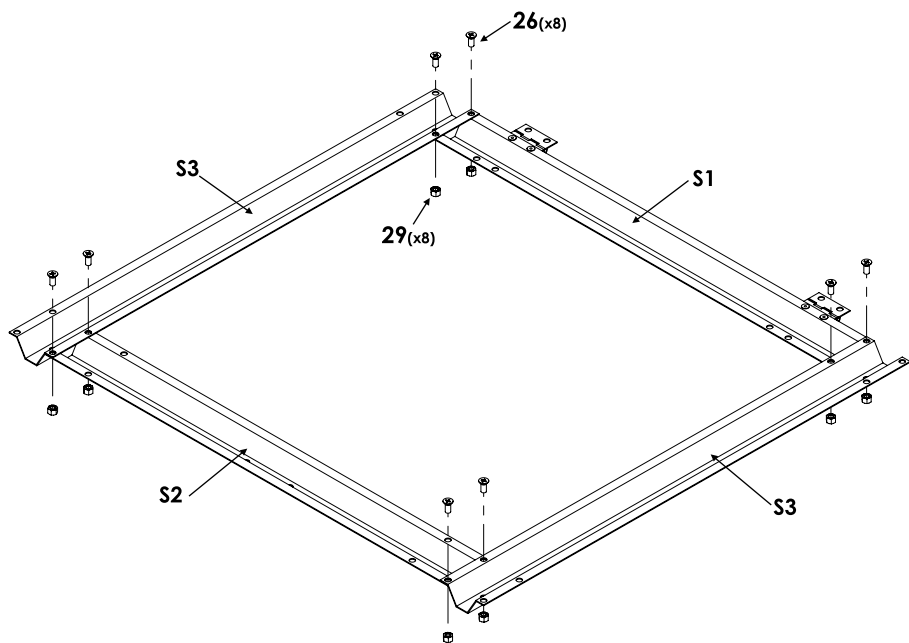

15

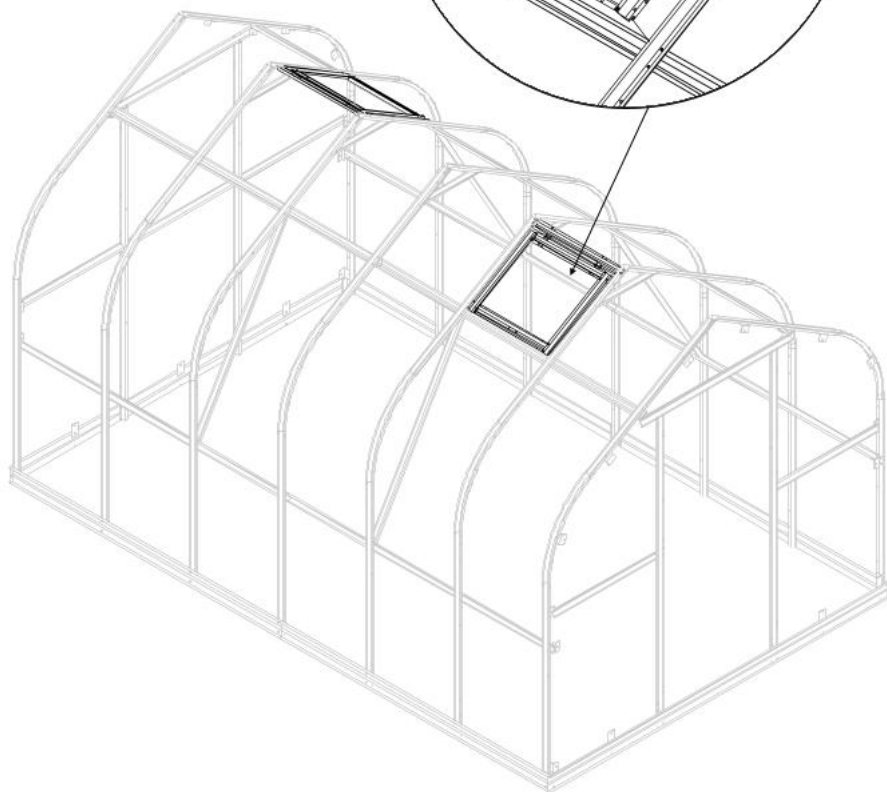
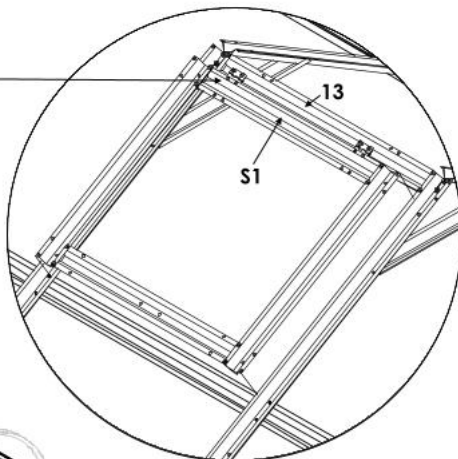
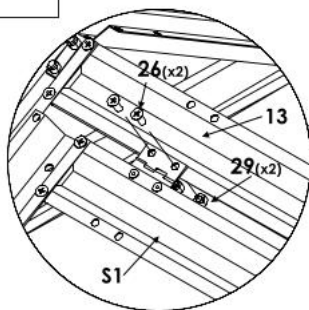

Polykarbonátová deska /
Polykarbonátová doska /
Polikarbonát lemez

16

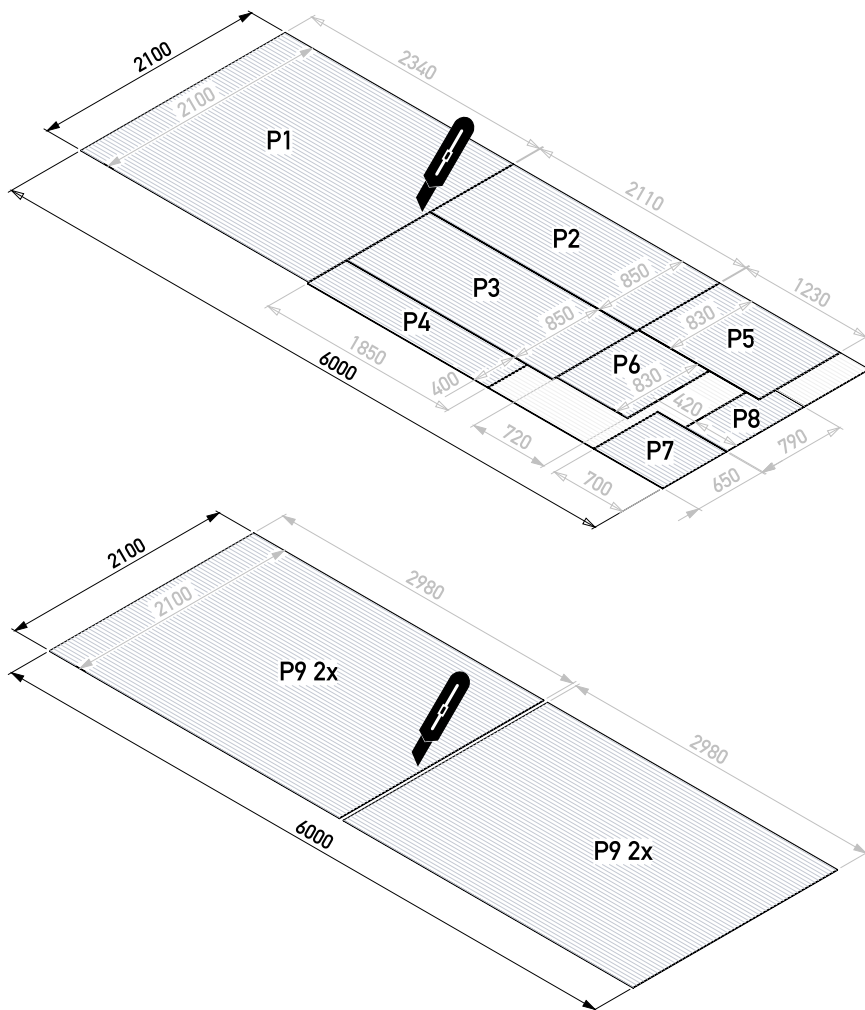

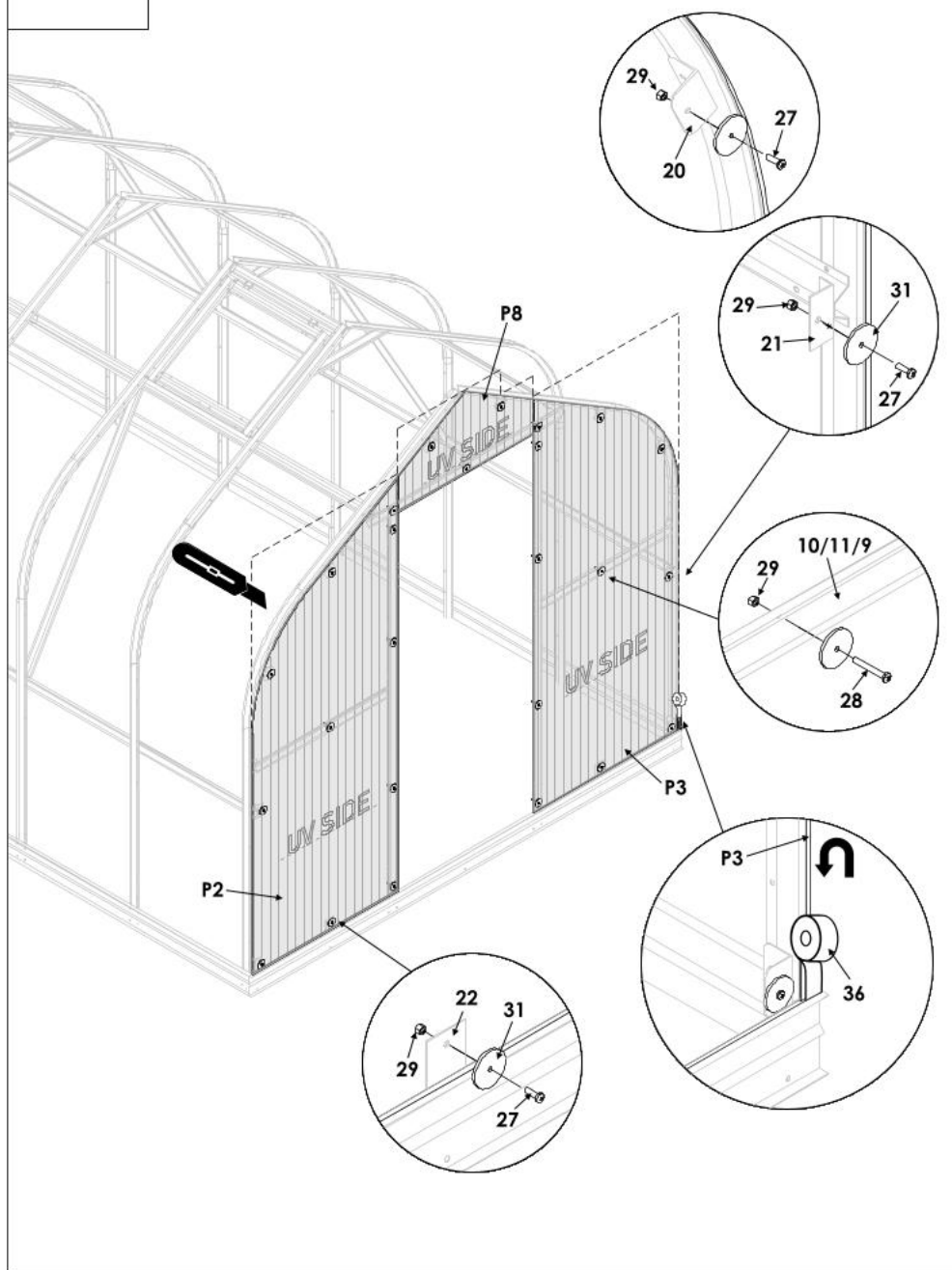

18

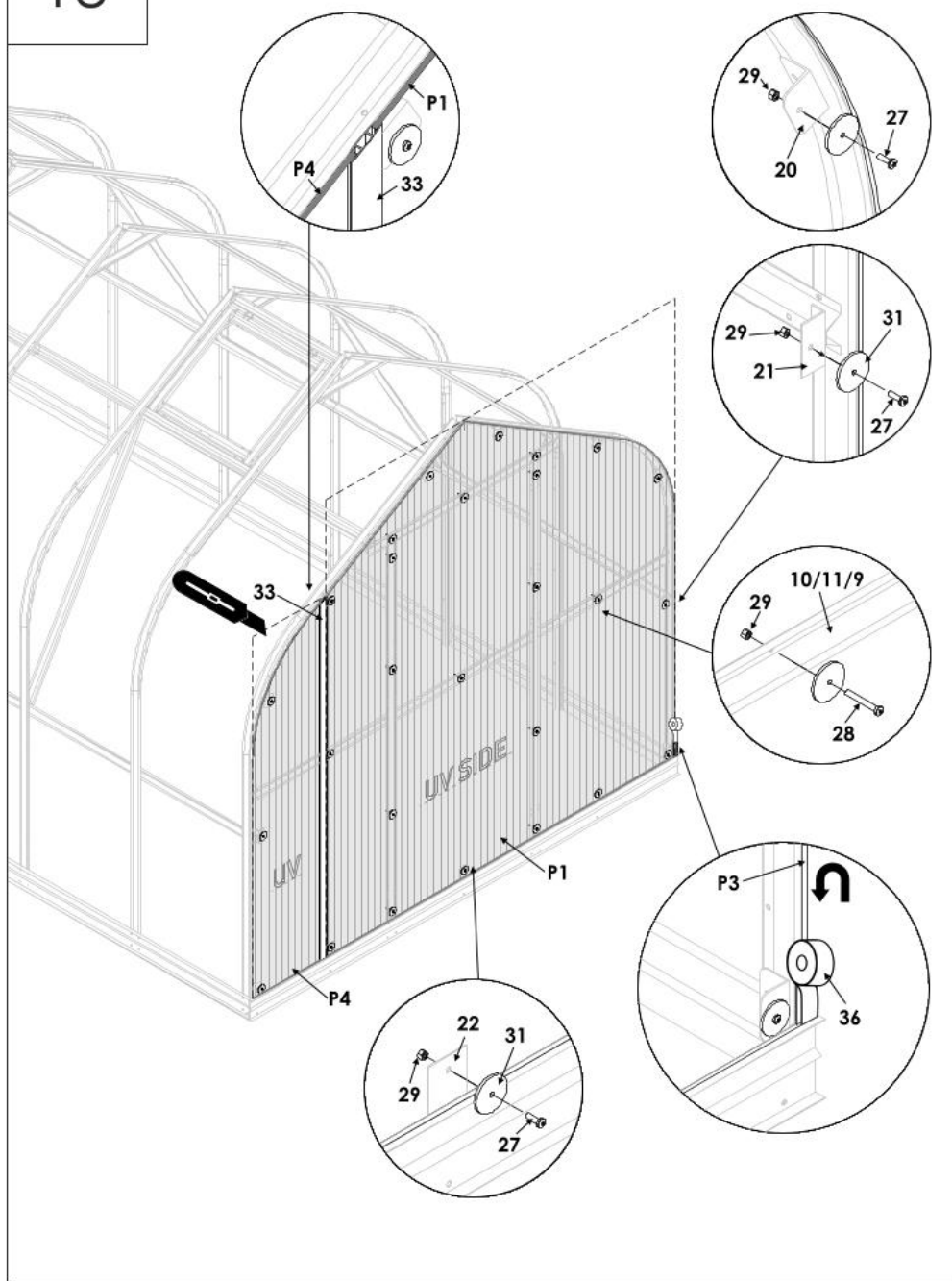

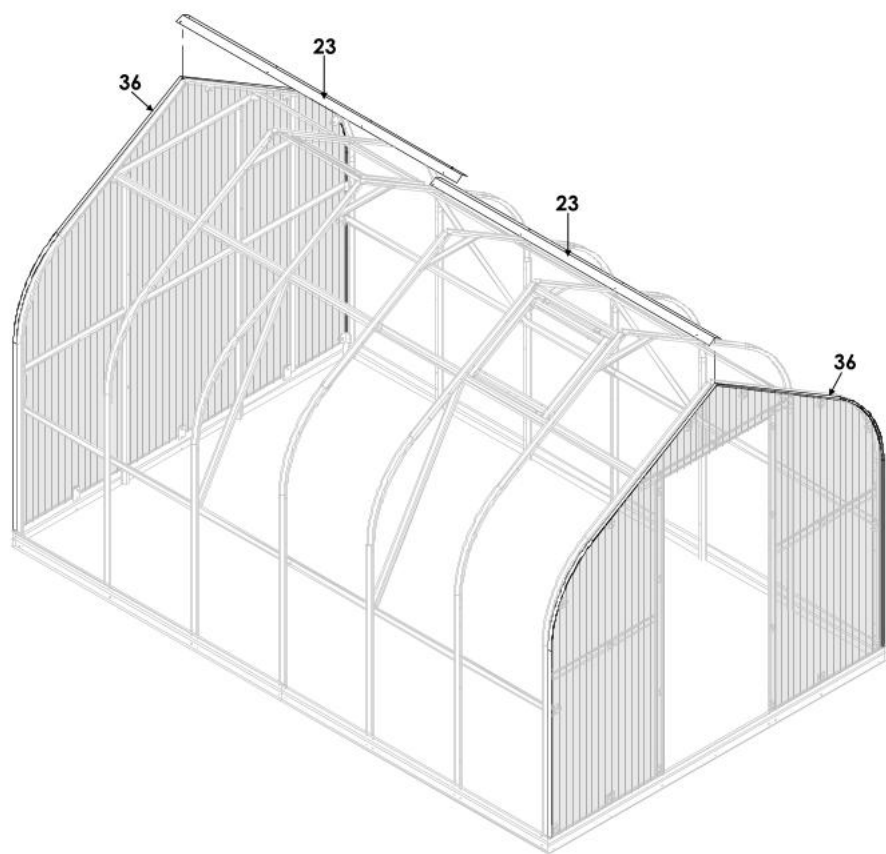

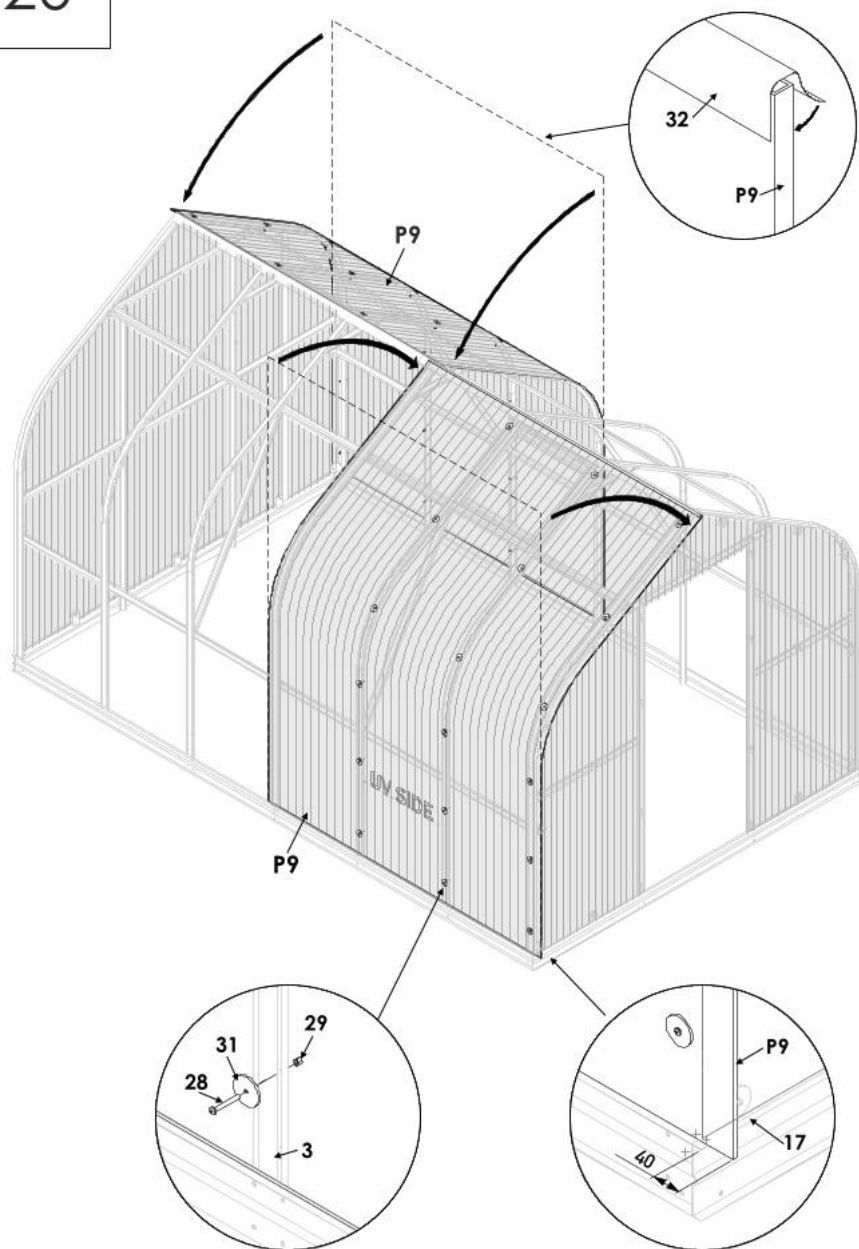

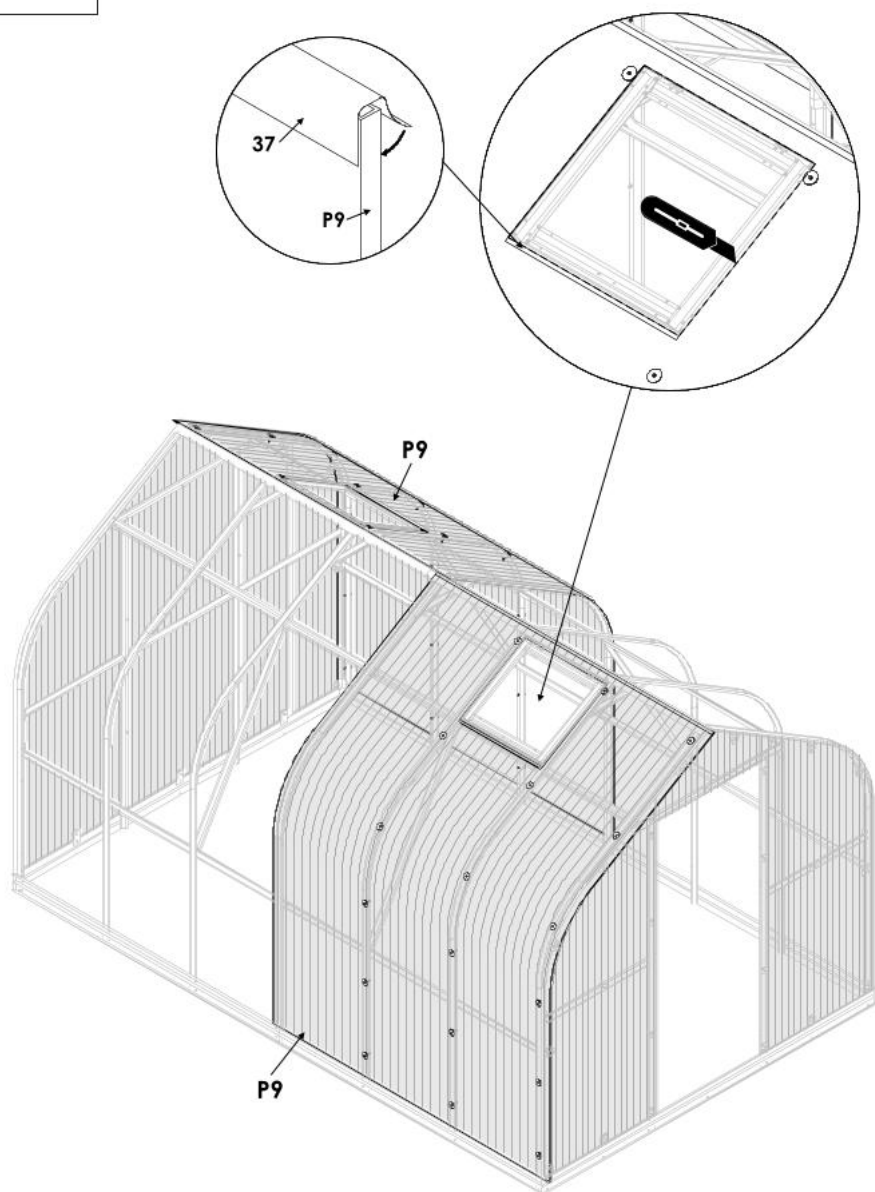

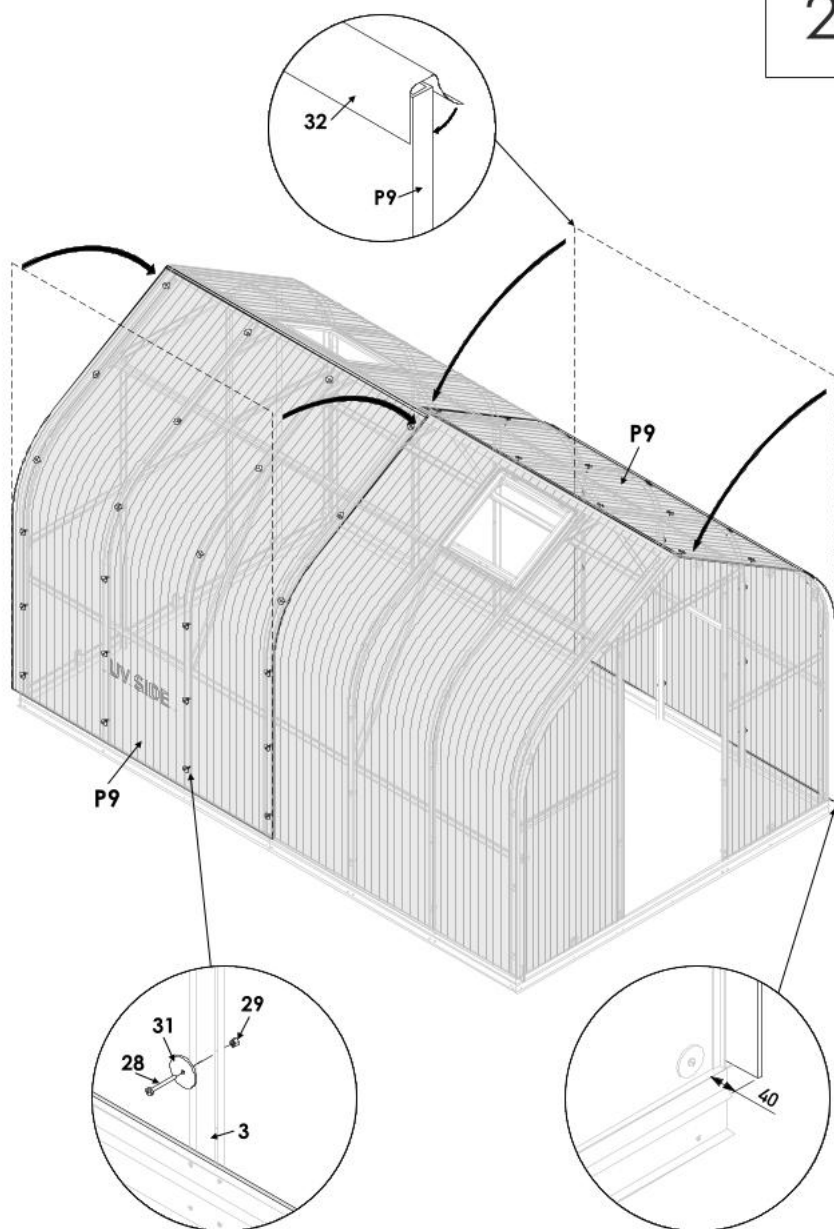

23

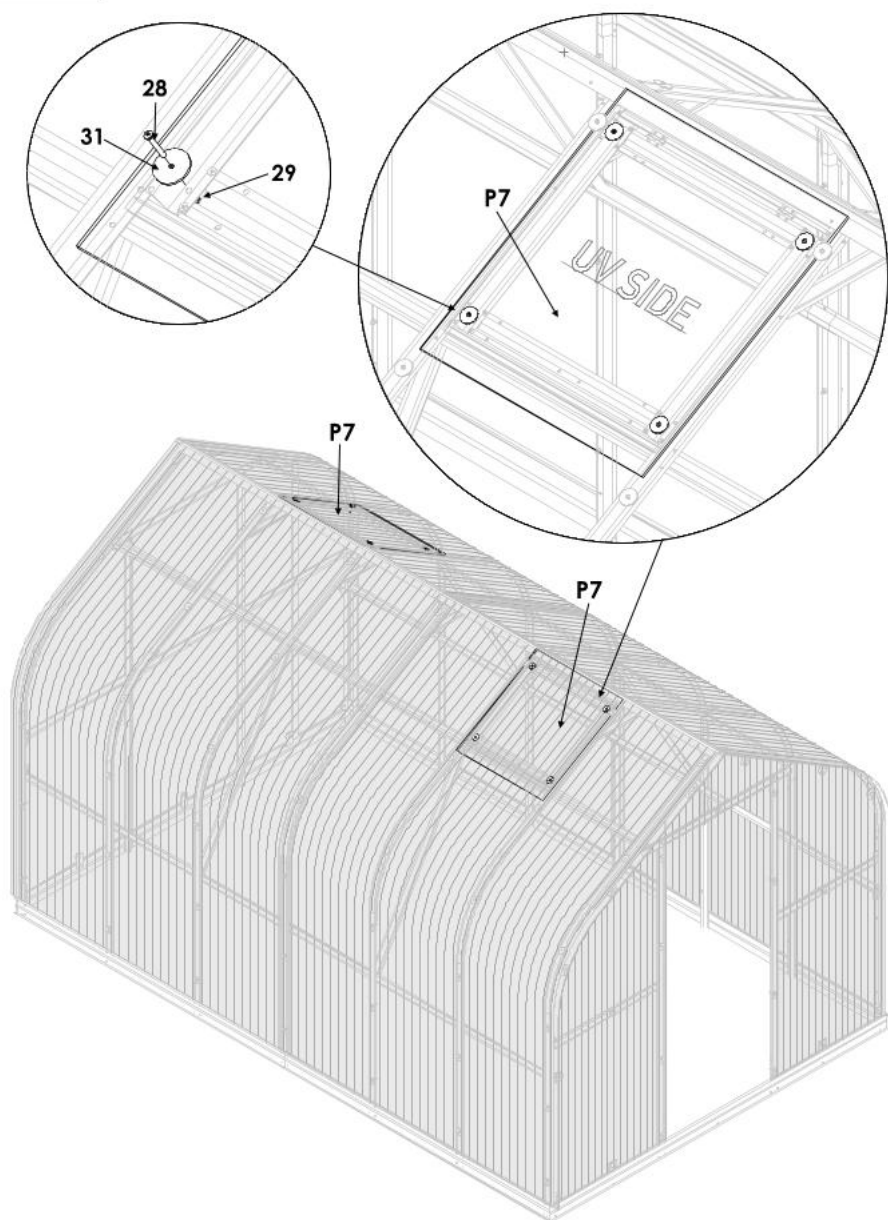

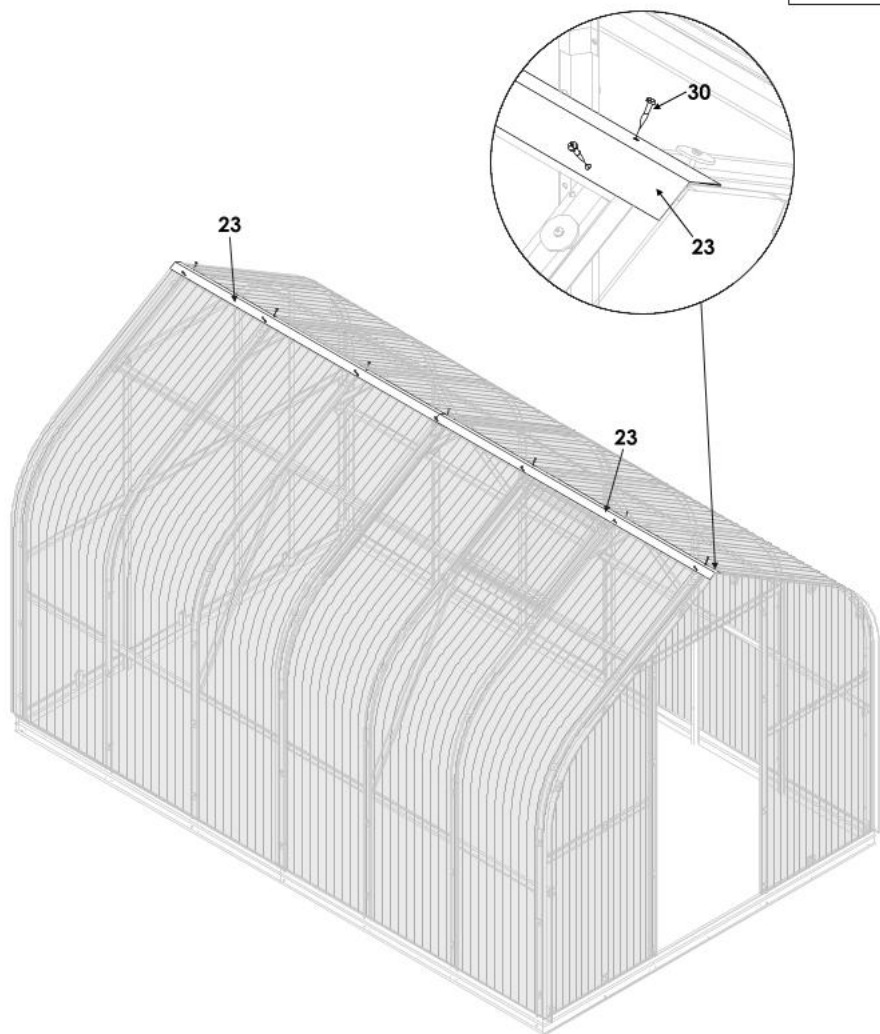

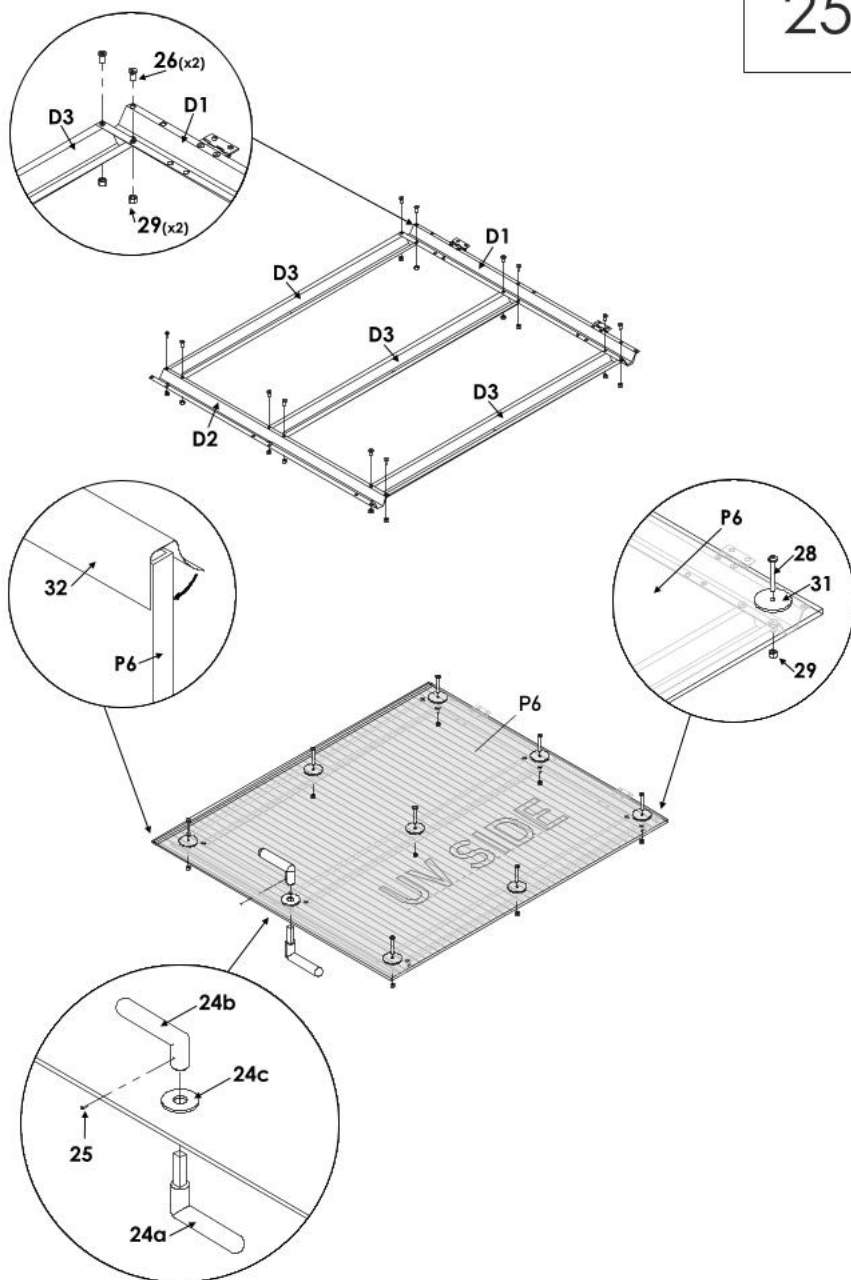

26

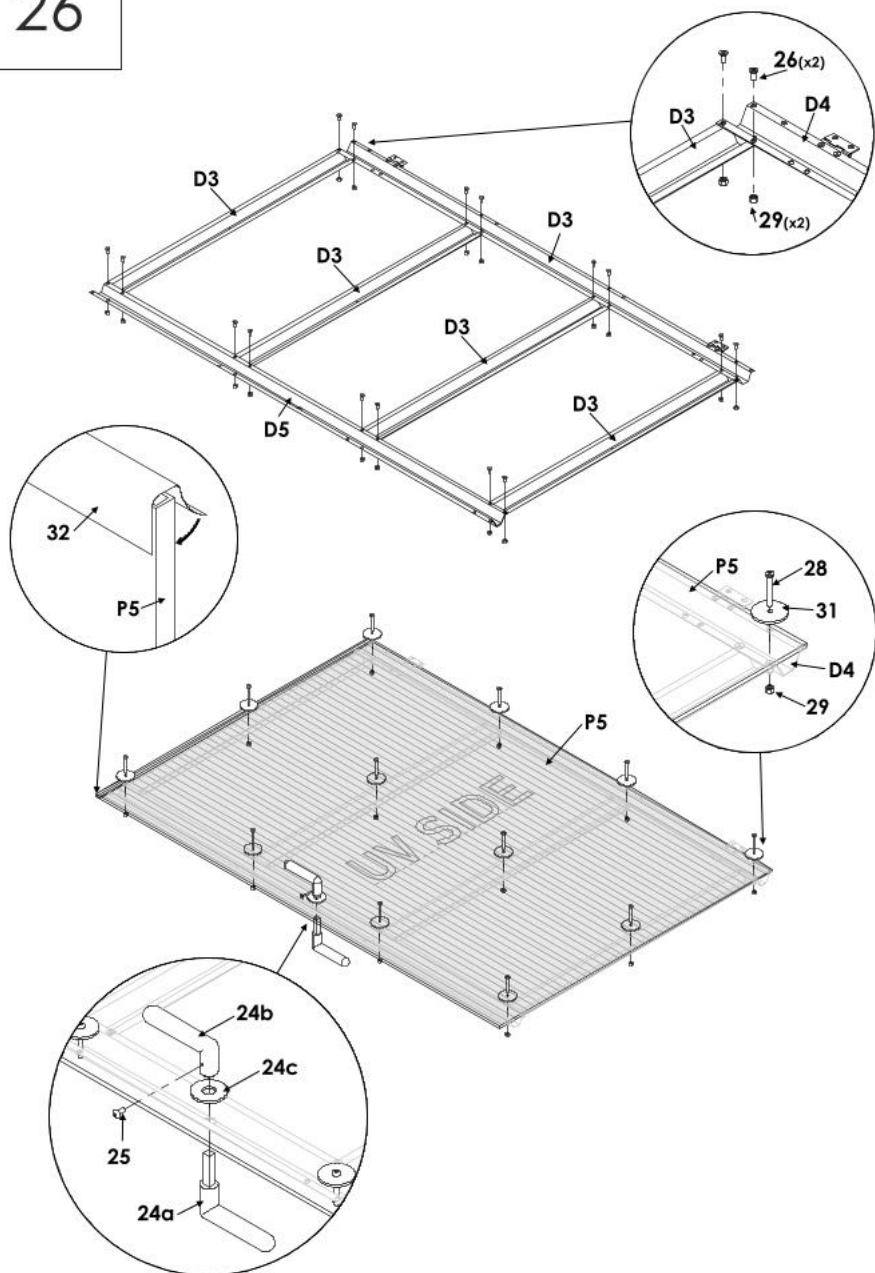

27

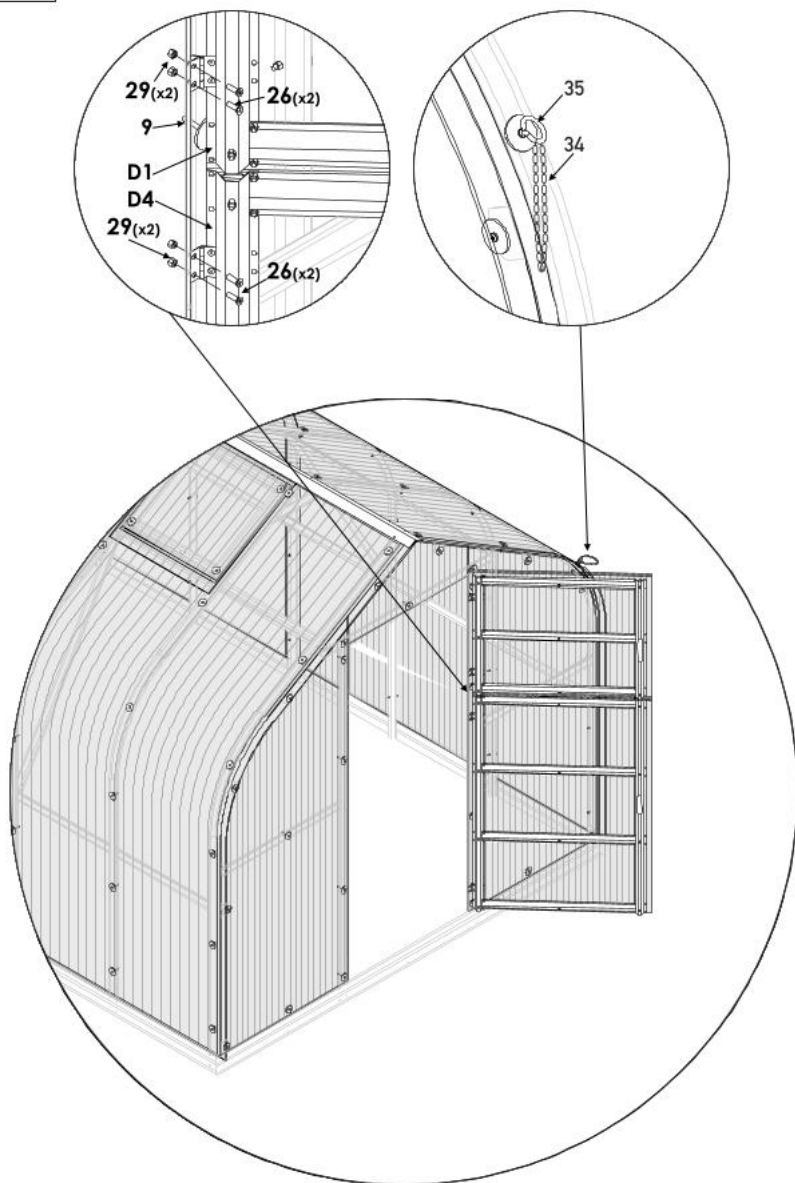

kiwa

No. 2268



EN 1090-1:2009+A1:2011
No. 2268-CPR-419



ZAHRADA JEŽEK

www.zahradajezek.cz
info@zahradajezek.cz



OD SUSEDA

www.odsuseda.sk
info@odsuseda.sk



JEZA

www.jeza.hu
info@jeza.hu

Distributor:

Dům a zahrada Ježek s.r.o.
Ledce 99, 330 14 Ledce u Plzně
CZECH REPUBLIC
VAT: CZ02906007